

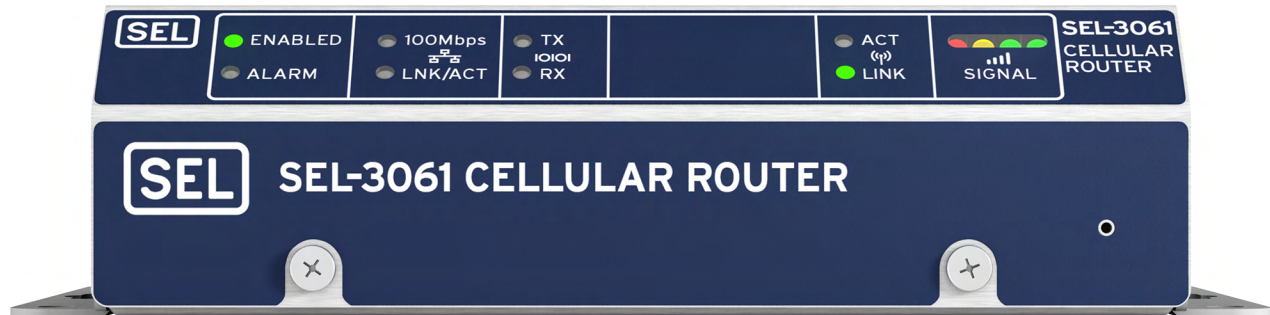

SEL-3061 Cellular Router

Secure Cellular Connectivity



Key Features and Benefits

The SEL-3061 Cellular Router provides secure wireless connectivity to a variety of critical infrastructure devices through the use of cellular networks. With a high data rate, the SEL-3061 serves as a communications backhaul for systems that need communications links to centralized locations. The router supports 4G LTE and 3G cellular technologies.

- **Multiple Carrier Support.** Supports AT&T, Verizon, T-Mobile, Rogers, Bell, and Telus networks.
- **Strong Secure Communication.** Offers as many as five concurrent IPsec VPN connections. X.509 certificates ensure strong authentication with third-party validation.
- **User-Based Accounts with Centralized User-Based Authentication.** Provides separate role-based authorization levels for configuration, maintenance, and usage. Supports Remote Authentication Dial-In User Service (RADIUS).
- **Syslog.** Logs system events for alerts in a consistent fashion for both local and centralized collection.
- **Network Management.** Supports SNMP reads and traps for versions v1, v2c, and v3.
- **Application Versatility.** Serial and Ethernet ports enable communications with a variety of end devices.
- **Dual-Mode Operation.** Gives flexibility of operating as a router or bridge.
- **Stateful Packet Inspection (SPI) Firewall and IP Defense.** Dynamic packet filtering prevents unauthorized traffic from entering your private network. Log all successful or blocked connections to the firewall. IP Defense mitigates the effects of denial-of-service and brute force attacks.
- **Ruggedness.** Provides utility-grade reliability. Designed and tested to relay standards for electromagnetic compatibility and surge immunity. Operates reliably between -40° to $+75^{\circ}\text{C}$ (-40° to 167°F).
- **Resiliency.** Enables the use of two antennas to increase performance.

Product Overview

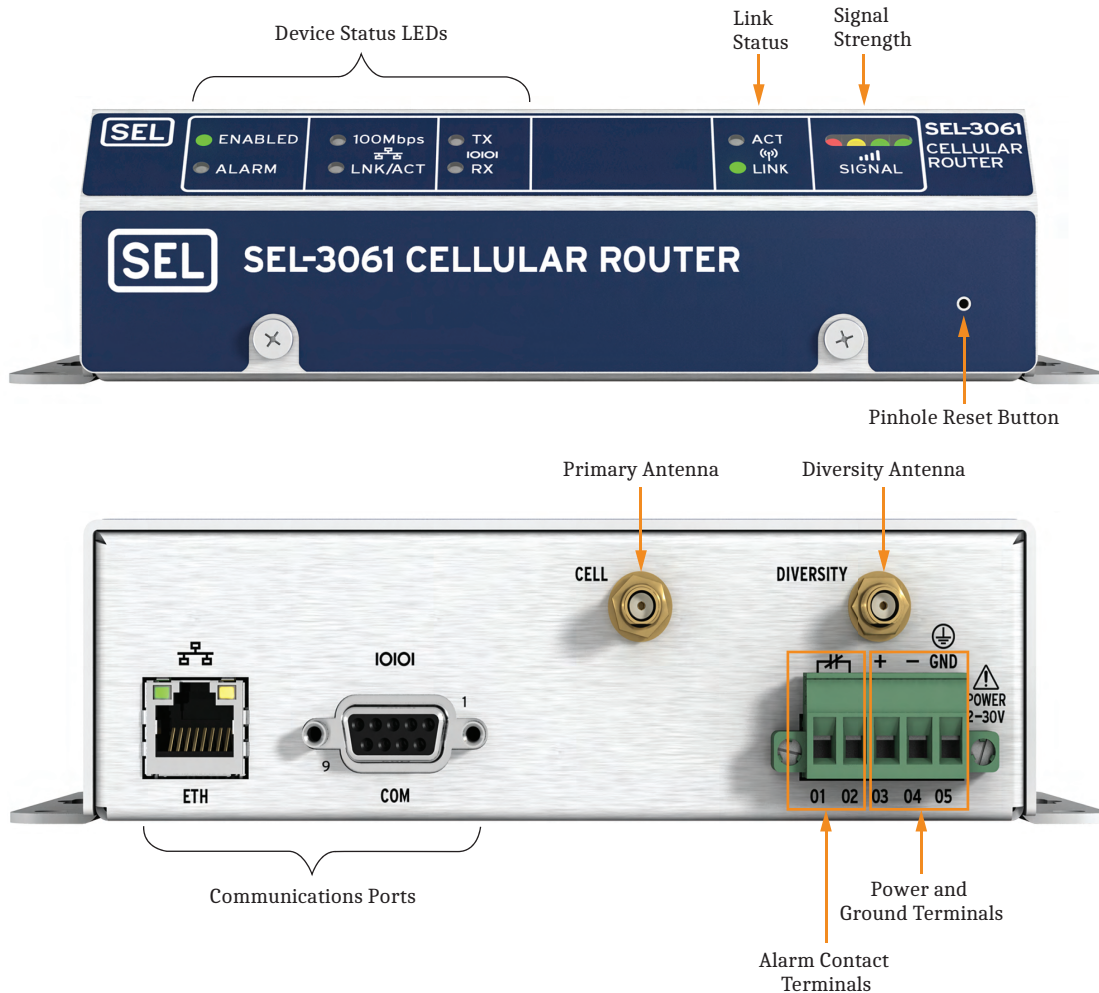

Figure 1 Product Overview

Features

Secure Communication Over Cellular Network

The SEL-3061 offers comprehensive security methods that include VPN, IPsec, SPI firewall, and media access control (MAC) address filtering to ensure the confidentiality and integrity of data communications over a cellular network. The SEL-3061 uses RADIUS and user account privileges to grant access to the device.

Device Management

The SEL-3061 simplifies device monitoring and management via the web interface of the router including over-the-air settings changes and firmware upgrades.

Ubiquitous Connectivity

The SEL-3061 supports 4G LTE and 3G cellular technology and uses cellular networks to provide wireless connectivity for a variety of critical infrastructure devices.

Reporting and Alarms

The SEL-3061 uses the Syslog format to log events. The router maintains an internal record of as many as 30,000 event logs in nonvolatile memory that can be downloaded into a CSV file. The Syslog supports two Syslog servers. Notifications and alarms can be triggered by the events and sent by using either SNMP, email, or short

these devices to a SCADA system via cellular WAN connections and allows the SCADA to poll each device by using DNP3 over TCP/IP and Modbus TCP/IP.

Engineering Access

The SEL-3061 allows users to access IEDs to view and modify settings and download oscillographic event reports through VPNs.

Distributed Data Acquisition

Modern automation systems can be distributed over a large geographical area. These automation systems monitor and process input signals, execute logic, and enable or disable outputs. In some instances, it is necessary to perform data acquisition on the status or value of the connected I/O. A distributed data acquisition system uses an automation controller as the data concentrator and a computer as the SCADA host. The system uses remote, discrete, and analog I/Os. As shown in *Figure 3*, a single SEL-3061 at each site both provides the connectivity between these remote I/Os with the automation controller and backhauls the collected data to the SCADA computer.

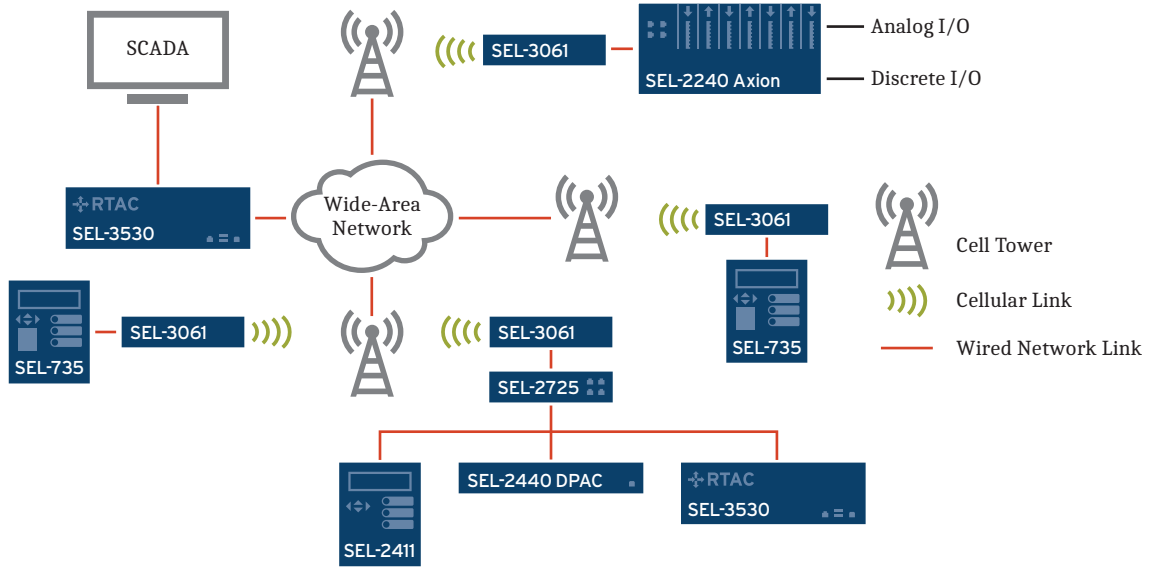

Figure 3 SCADA, Engineering Access, and Distributed Data Acquisition

Distribution Automation

The SEL-3061 provides cellular connectivity to remotely monitor and control recloser controls and sectionalizers for distribution power systems, as shown in *Figure 4*. In cases where customers rely on communications schemes for power restoration, the SEL-3061 provides the con-

nectivity. The main difference between the distribution automation (DA) systems that use line-of-sight radios and DA systems that use an SEL-3061 is that the SEL-3061 and DA can be installed at any IED location that has cellular coverage. The DA controller polls data from each recloser control for monitoring and sends control signals through the WAN and the SEL-3061.

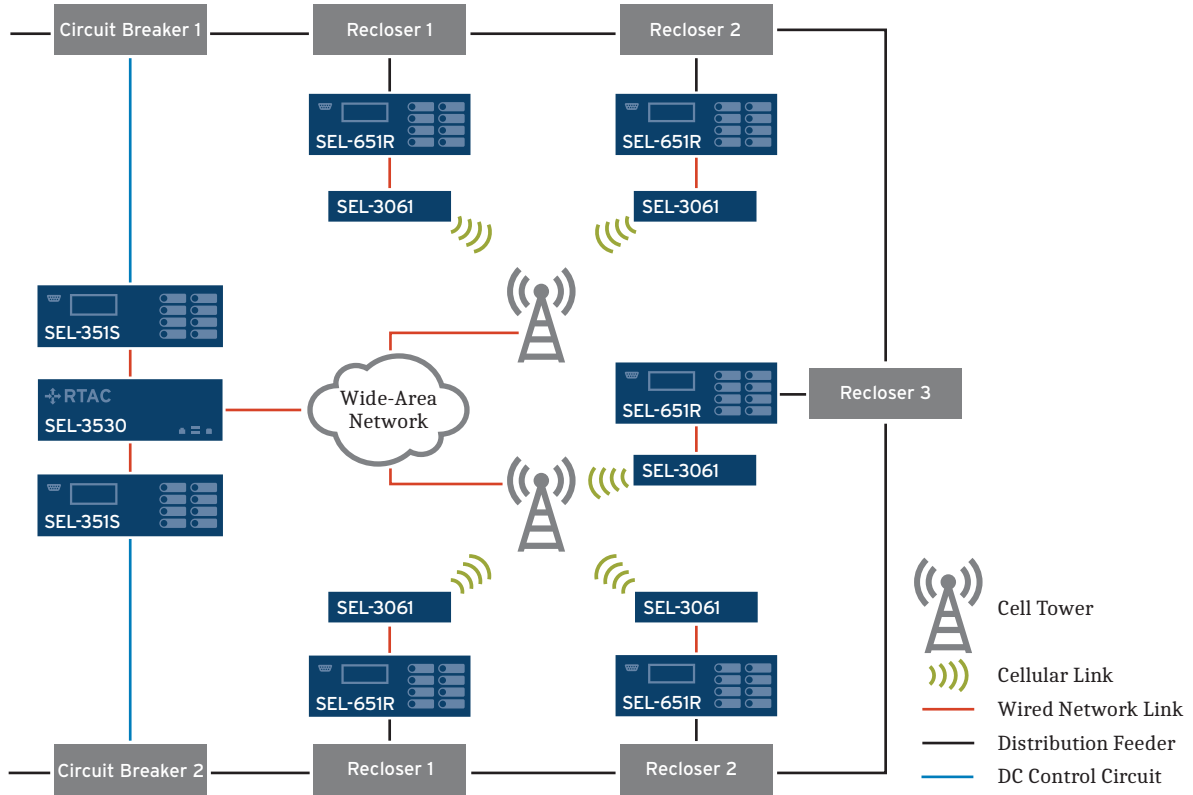

Figure 4 Distribution Automation

SEL-FLT/SEL-FLR Network Backhaul

The SEL-FLT and SEL-FLR Fault and Load Transmitter and Receiver System provides wide-area load monitoring and fault location from line-powered SEL-FLT devices. The SEL-FLR collects load data and fault information from the SEL-FLT devices and sends the collected data

to an Operation Management System (OMS) or Energy Management System (EMS) via a WAN. The SEL-3061 provides the communications link between the OMS and the SEL-FLR. When connected to the SEL-FLR the SEL-3061 provides wireless connectivity for the SEL-FLT/SEL-FLR networks, as illustrated in *Figure 5*.

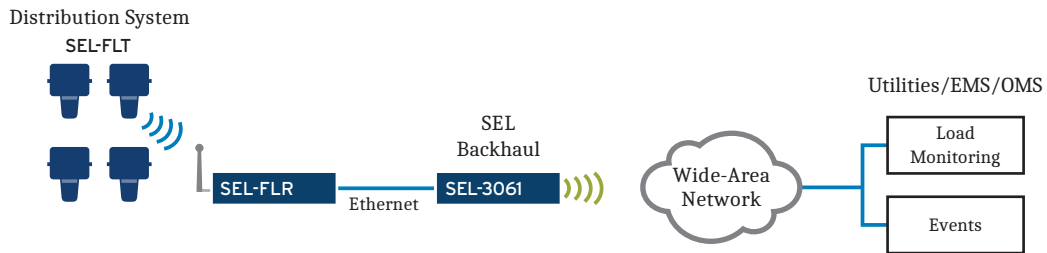

Figure 5 Backhaul Communication for Distribution Line Sensors

Distributed Generation

The SEL-3061 provides the connectivity to remotely monitor and control relays, devices, and equipment at distributed generation (DG) sites. In most applications, an automation controller interfaces with devices located inside the DG facility. The SEL-3061 can be connected to the controller to provide backhaul connectivity for devices located at the DG sites. The SEL-3061 is suitable for monitoring and non-protection speed control of the DG site.

Voltage Regulators

Voltage regulators installed outside the substation use the SEL-3061 to report their status and receive control commands from either a controller or the SCADA system. Connect the voltage regulator to the SEL-3061 by using either the serial or Ethernet interface.

Capacitor Bank Controls

The SEL-3061 provides communication for remote monitoring and automated or manual control of capacitor banks.

Pump Automation Controls

Monitor and control critical infrastructure, such as water and wastewater pumps, by using the SEL-3061 to provide remote access to SEL-241 IP Pump Automation Controllers. During both routine operations and natural disasters, the cellular network provides a reliable path from a control center to the field. Use an Ethernet switch to connect more than one controller to a single SEL-3061.

Network Backhaul

A radio or Advanced Metering Infrastructure (AMI) network usually has an access point that concentrates data from remote endpoints. The access point is usually connected to a WAN or another wireless network. The SEL-3061 can be used as the link between the access point and the WAN or the wireless network by providing backhaul for these networks.

Configuration

The SEL-3061 offers an easy-to-use web-based user interface to change router configuration settings, visualize router status, and manage reporting.

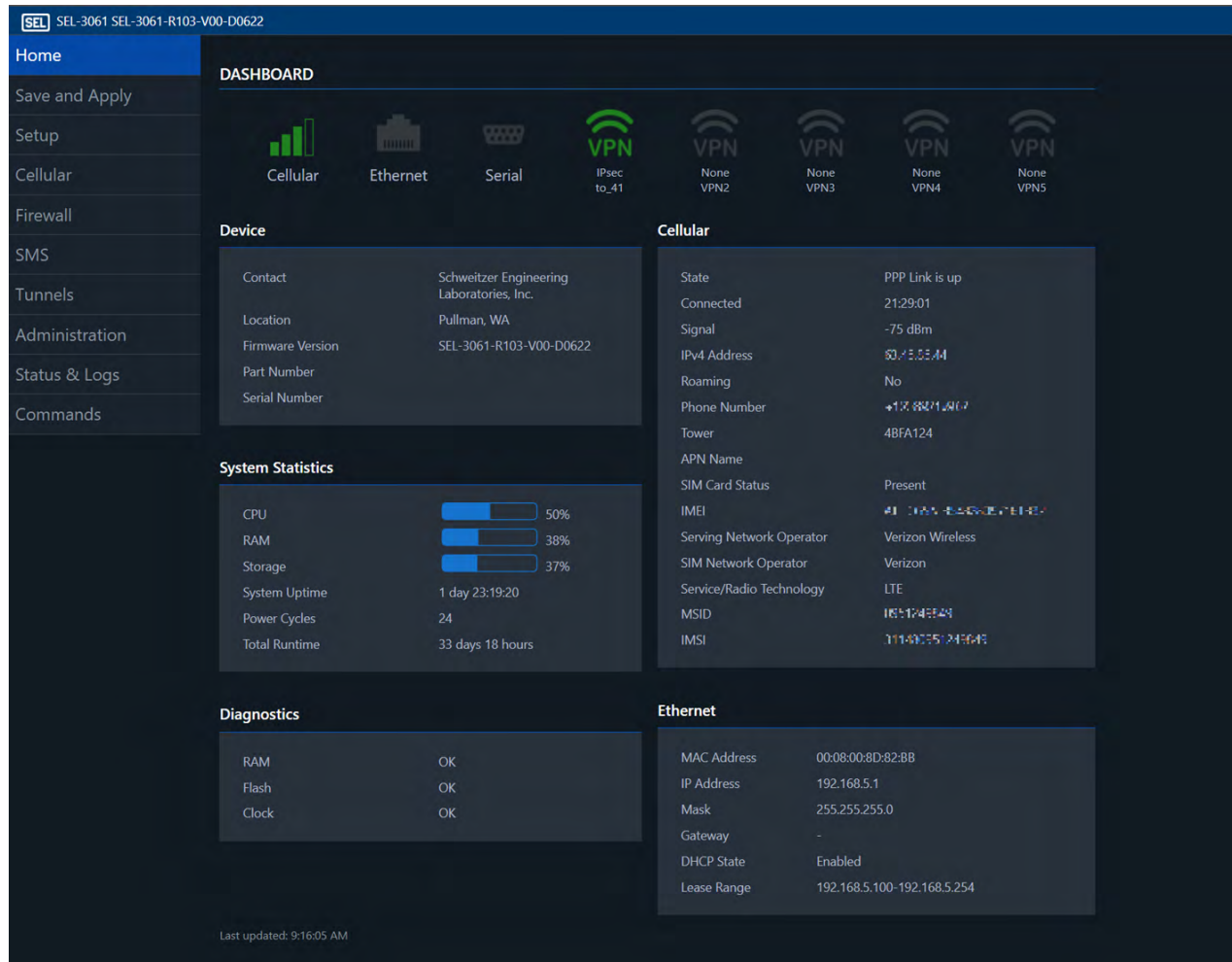

Figure 6 SEL-3061 HTTPS Device Webpage

Accessories

The following accessories are available for use with the SEL-3061.

Table 1 Available Antennas

| Part Number | Description |
|-------------|---|
| 235-0003 | Low-profile 3 dBi Omnidirectional, 698–960 MHz, 1710–2700 MHz, N Female Connector |
| 235-0242 | Indoor Right-Angle Antenna, 698–960 MHz, 1710–2700 MHz, SMA Male Connector |

Table 2 Optional Antenna Mounting Hardware

| Part Number | Description |
|-------------|--|
| 915900497 | Mounting bracket for two 235-0003 antennas |

Table 3 Signal Loss at 2155 MHz

| Cable Type | Characteristic Impedance | 3.05 m (10 ft) | 12.24 m (50 ft) | 30.48 m (100 ft) |
|-----------------------------------|--------------------------|----------------|-----------------|------------------|
| RG-8X (SEL-C980 or SEL-C964) | 50 Ω | 2.0 dB | 10.1 dB | Do Not Use |
| LMR-400 (SEL-C966 or SEL-C968) | 50 Ω | 0.6 dB | 3.1 dB | 6.2 dB |
| 7/8" HELIAX (SEL-C978) | 50 Ω | Do Not Use | 0.97 dB | 1.94 dB |

For more information on the SEL-3061 accessories and antenna installation, refer to the *SEL-3061 Instruction Manual* or the *SEL Radio Accessories Guide*.

Diagrams and Dimensions

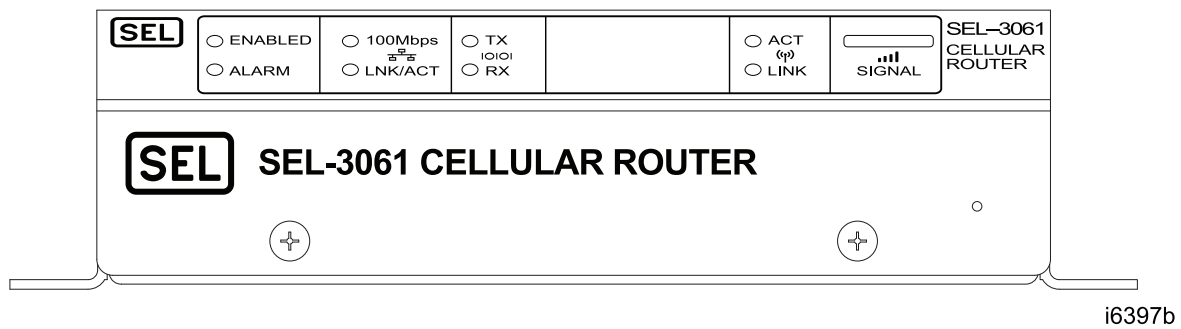

Figure 7 SEL-3061 Front-Panel Diagram

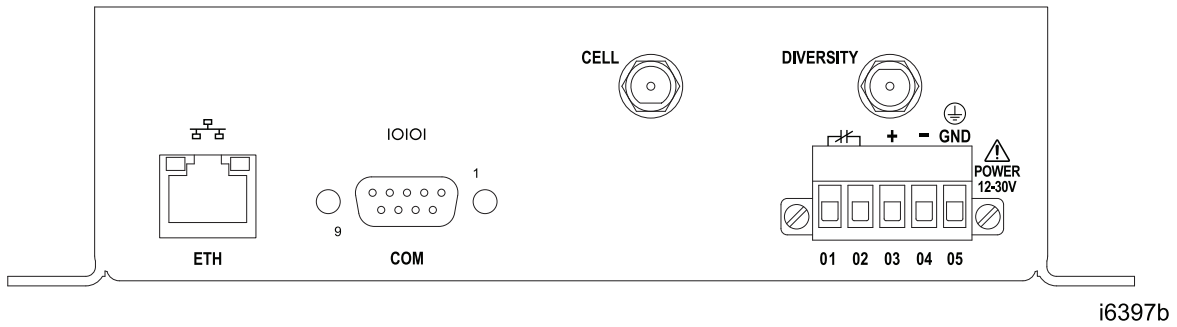

Figure 8 SEL-3061 Rear-Panel Diagram

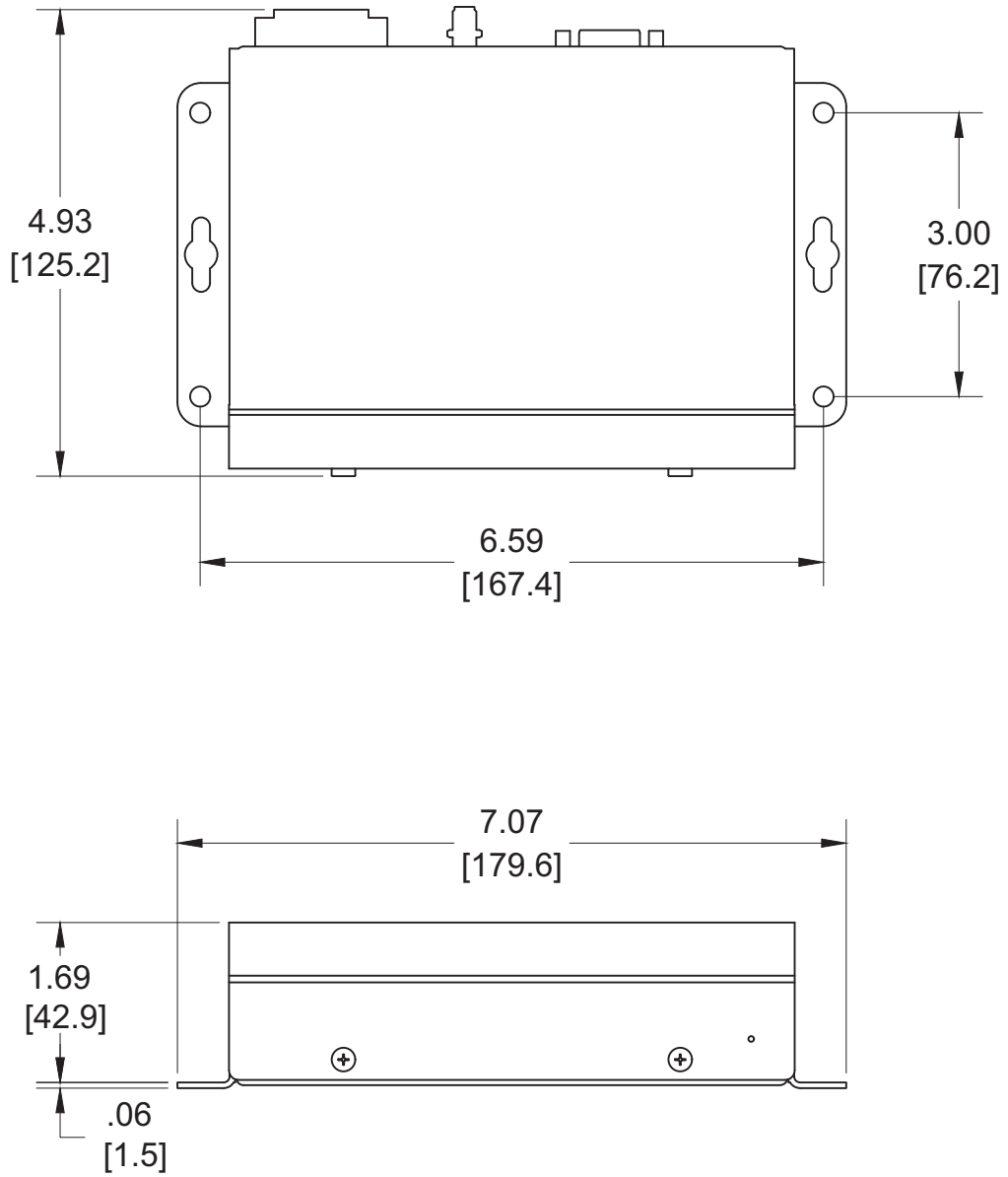

Figure 9 SEL-3061 Dimensions for Rack- and Panel-Mount Models

Specifications

Compliance

Designed and manufactured under an ISO 9001 certified quality management system

Networking

Network Management

HTTPS Web User Interface

Settings Import/Export

Virtual Private Networks

| | |
|---------------------------------------|------------------|
| Maximum Concurrent Sessions: | 5 |
| Security Protocol: | IPsec |
| Key Exchange: | IKEv1, IKEv2 |
| Authentication: | Passphrase |
| Nonaccelerated Encryption Algorithms: | AES, 3DES |
| Encryption Key Strength: | 128-bit, 256-bit |

Firewall Functions

| | |
|------------------------------|------------------------|
| Network Address Translation: | Port Forwarding (DNAT) |
| Network Address Translation: | Outbound NAT (SNAT) |
| Input Traffic Filtering | |
| Output Traffic Filtering | |
| Forward Traffic Filtering | |

Ethernet Protocols

| |
|--|
| Address Resolution Protocol (ARP) |
| Distributed Network Protocol 3 (DNP3) |
| Dynamic Host Configuration Protocol (DHCP) Client |
| Encapsulating Security Payload (ESP) |
| File Transfer Protocol (FTP) |
| Hypertext Transfer Protocol Secure (HTTPS) |
| Internet Control Message Protocol (ICMP) |
| Internet Key Exchange (IKEv1/v2) |
| Internet Protocol Security (IPsec) Protocol Suite |
| Internet Secure Association and Key Management Protocol (ISAKMP) |
| Modbus TCP/IP |
| Network Time Protocol (NTP) Client |
| Online Certificate Revocation Protocol (OCSP) |
| Remote Authentication Dial-In User Service (RADIUS) |
| Secure Shell version 2 (SSHv2) Client/Server |
| Simple Network Management Protocol (SNMP) |
| Spanning Tree Protocol (STP) Syslog |
| Transmission Control Protocol (TCP) |
| Transport Layer Security (TLS) |
| User Datagram Protocol (UDP) |

Security

User-Based Accounts

| | |
|------------------|-----------------------------------|
| Password Length: | 8–4096 characters |
| Password Set: | A–Z, a–z, 0–9, special characters |
| User Roles: | Administrator, Engineer, Monitor |

Syslog

Storage for 30,000 local Syslog messages

SNMP

Monitors diagnostics through SNMP v1, v2c, and v3 read operations
Sends notifications by using SNMP v1, v2c, and v3 traps
Supports as many as three active SNMP servers and SNMP trap servers

Firewall

Implementation: iptables

Cellular WAN

| | |
|---------------------------------|--|
| Frequency Band (MHz): | 4G: 700 (B17)/850 (B5)/AWS1700 (B4)/1900 (B2)/700 (B13) |
| 3G/2G (AT&T and T-Mobile Only): | 850 (B5)/1900 (B2) |
| Technology: | 4G, LTE 3G/2G fallback (AT&T and T-Mobile only) when available by the carrier |

Data Rate

As much as 100 Mbps downlink

As much as 50 Mbps uplink

Transmit Output Power

0.2 W (23 dBm), Class 3

General

Operating Temperature

–40° to +75°C (–40° to +167°F)

Storage Temperature

–40° to +75°C (–40° to +167°F)

Operating Environment

| | |
|--------------------|------------------------|
| Pollution Degree: | 2 |
| Relative Humidity: | 15%–93%, noncondensing |
| Maximum Altitude: | 2000 m |

Dimensions

| | |
|-------------|--|
| Wall Mount: | 151 mm x 104 mm x 44 mm (5.96 in x 4.08 in x 1.73 in) |
|-------------|--|

Alarm Output

| | |
|----------------------------|------------------------|
| Rated Operational Voltage: | 24–250 Vdc |
| Contact Protection: | 270 Vdc, MOV protected |
| Continuous Carry: | 2 A |
| Pickup Time: | ≤8 ms typical |
| Dropout Time: | ≤8 ms typical |

Communications Ports

Ethernet Port

| | |
|--------------------------------------|------------|
| Port: | 1, rear |
| 10/100BASE-T Copper (RJ45 Connector) | |
| Rear Connectors: | RJ45 |
| Standard: | IEEE 802.3 |

Serial Port

| | |
|------------------|---|
| Port: | 1 EIA-232 |
| Rate: | 300 bps, 600 bps, 1200 bps, 1800 bps, 2400 bps, 4800 bps, 9600 bps, 19200 bps, 38400 bps, and 57600 bps |
| Rear Connectors: | 9-pin D-Subminiature |

Power Supply

| | |
|----------------------|-----------|
| Input Voltage Range: | 12–30 Vdc |
| Power Consumption: | <5 W |

Product Standards

| | |
|--|-------------------|
| Measuring Relays and Protection Equipment: | IEC 60255-26:2013 |
|--|-------------------|

Note: Tests apply to the SEL-3061 only and not to data transfer over the cellular WAN.

Type Tests

Environmental Tests

| | |
|-----------------------|---|
| Vibration Resistance: | IEC 60255-21-1:1988 Class 2 Endurance, Class 2 Response IEC 60255-21-3:1993 Class 2 |
| Shock Resistance: | IEC 60255-21-2:1988 Class 1 Shock Withstand Bump, Class 2 Shock Response |
| Cold: | IEC 60068-2-1:2007 –40°C, 16 hours |
| Damp Heat, Cyclic: | IEC 60068-2-30:2005 25–55°C, 95% relative humidity, 6 cycles |
| Dry Heat: | IEC 60068-2-2:2007 +75°C, 16 hours |

Dielectric Strength and Impulse Tests

| | |
|---------------------|---|
| Dielectric (HiPot): | IEC 60255-27:2013 IEEE C37.90-2005 |
| Impulse: | IEC 60255-5:2000 0.5 J, 5 kV 1.0 kV on Ethernet Ports |

RFI and Interference Test

| | |
|---------------------------------|--|
| Electrostatic Discharge: | IEC 61000-4-2:2009 Severity Level 4 8 kV contact discharge 15 kV air discharge IEEE C37.90.3-2001 Severity Level 3 8 kV contact discharge 15 kV air discharge |
| Radiated RF Immunity: | IEC 61000-4-3:2005+A1:2008+A2:2010 10 V/m |
| Fast Transient Burst Immunity: | IEC 61000-4-4:2012 4 kV @ 5.0 kHz for power port 2 kV @ 5.0 kHz for communications ports |
| Power Frequency Magnetic Field: | IEC 61000-4-8:2009 1000 A/m for 3 seconds, 100 A/m for 1 minute |
| Interruptions and Voltage: | IEC 61000-4-11:2004 +A1:2017 |
| Variations on DC Input: | IEC 61000-4-17:1999+A1:2001+A2:2008 |
| Power Port: | IEC 61000-4-29:2000 |
| Surge Withstand: | IEC 61000-4-18:2005+A1:2010 |
| Capability Immunity: | 2.5 kV common-mode, 1 kV differential-mode |
| Conducted RF Immunity: | IEC 61000-4-6:2013 10 Vrms |
| Surge Immunity: | IEC 61000-4-5:2005 Zone B: 0.5; 1.0 kV; line-to-line Zone B: 0.5; 1.0; 2.0 kV; line-to-earth |

EMC Emissions

| | |
|---------------------|--|
| Radiated Emissions: | CISPR 11:2009+A1:2010 CISPR 22:2008 ANSI C63.4:2015 47 CFR Part 15.107, 109 |
|---------------------|--|

This device complies with Part 15 of the FCC rules. Operation is subject to the following two conditions:

1. This device may not cause harmful interference, and
2. This device must accept any interference received, including interference that may cause undesired operation.

FCC Part 15, Class A

Note: This equipment has been tested and found to comply with the limits for a Class A digital device, pursuant to Part 15 of the FCC Rules. These limits are designed to provide reasonable protection against harmful interference when the equipment is operated in a commercial environment.

This equipment generates, uses, and can radiate radio frequency energy and, if not installed and used in accordance with the instruction manual, may cause harmful interference to radio communications.

Operation of this equipment in a residential area is likely to cause harmful interference in which case the user will be required to correct the interference at his own expense.

FCC Section 15.21

User's manual for an intentional or unintentional radiator shall caution the user that changes or modifications not expressly approved by the party responsible for compliance could void the user's authority to operate the equipment.

Canada ICES-001(A) / NMB-001(A)

Technical Support

We appreciate your interest in SEL products and services. If you have questions or comments, please contact us at:

Schweitzer Engineering Laboratories, Inc.
2350 NE Hopkins Court
Pullman, WA 99163-5603 U.S.A.
Tel: +1.509.338.3838
Fax: +1.509.332.7990
Internet: selinc.com/support
Email: info@selinc.com

© 2018-2022 by Schweitzer Engineering Laboratories, Inc. All rights reserved.

All brand or product names appearing in this document are the trademark or registered trademark of their respective holders. No SEL trademarks may be used without written permission. SEL products appearing in this document may be covered by U.S. and Foreign patents.

Schweitzer Engineering Laboratories, Inc. reserves all rights and benefits afforded under federal and international copyright and patent laws in its products, including without limitation software, firmware, and documentation.

The information in this document is provided for informational use only and is subject to change without notice. Schweitzer Engineering Laboratories, Inc. has approved only the English language document.

This product is covered by the standard SEL 10-year warranty. For warranty details, visit selinc.com or contact your customer service representative.

SCHWEITZER ENGINEERING LABORATORIES, INC.

2350 NE Hopkins Court • Pullman, WA 99163-5603 U.S.A.
Tel: +1.509.332.1890 • Fax: +1.509.332.7990
selinc.com • info@selinc.com

